



# Board of Adjustment Staff Report

Meeting Date: September 2, 2021

Agenda Item: 8F

SPECIAL USE PERMIT CASE NUMBER: WSUP21-0020 (St Nicholas Academy)

BRIEF SUMMARY OF REQUEST: Establish a private school

STAFF PLANNER: Planner's Name: Roger Pelham, MPA, Senior Planner  
Phone Number: 775.328.3622  
E-mail: [rpelham@washoecounty.us](mailto:rpelham@washoecounty.us)

### CASE DESCRIPTION

For hearing, discussion and possible action to approve the establishment of a private school including three temporary modular classroom buildings. The applicant is also requesting to eliminate all required parking and landscaping standards.

Applicant:	St Nicholas Orthodox Academy
Property Owner:	JLC Realty, LLC
Location:	16255 South Virginia St
APN:	045-210-01
Parcel Size:	13.96 acres
Master Plan:	Rural Residential
Regulatory Zone:	High Density Rural
Area Plan:	South Valleys
Development Code:	Authorized in Article 810
Commission District:	2 – Commissioner Lucey



Vicinity Map

### STAFF RECOMMENDATION

APPROVE

**APPROVE WITH CONDITIONS**

DENY

### POSSIBLE MOTION

I move that, after giving reasoned consideration to the information contained in the staff report and information received during the public hearing, the Washoe County Board of Adjustment approve Special Use Permit Case Number WSUP21-0020 for St. Nicholas Orthodox Academy, with the conditions included as Exhibit A to this matter, and does not vary any generally applicable development standards, having made all five findings in accordance with Washoe County Code Section 110.810.30.

*(Motion with Findings on Page 10)*

**Staff Report Contents**

Special Use Permit..... 3

Site Plan..... 4

Project Evaluation ..... 5

Area Plan Evaluation..... 8

Reviewing Agencies ..... 9

Recommendation .....10

Motion .....10

Appeal Process .....11

.....

**Exhibits Contents**

Conditions of Approval .....Exhibit A

Agency Comments .....Exhibit B

Project Application.....Exhibit C

Public Notice .....Exhibit D

**Special Use Permit**

The purpose of a special use permit is to allow a method of review to identify any potential harmful impacts on adjacent properties or surrounding areas for uses that may be appropriate within a regulatory zone; and to provide for a procedure whereby such uses might be permitted by further restricting or conditioning them so as to mitigate or eliminate possible adverse impacts. If the Board of Adjustment grants an approval of the special use permit, that approval is subject to conditions of approval. Conditions of approval are requirements that need to be completed during different stages of the proposed project. Those stages are typically:

- Prior to permit issuance (i.e. a grading permit, a building permit, etc.)
- Prior to obtaining a final inspection and/or a certificate of occupancy on a structure
- Prior to the issuance of a business license or other permits/licenses
- Some conditions of approval are referred to as “operational conditions.” These conditions must be continually complied with for the life of the business or project.

The conditions of approval for Special Use Permit Case Number WSUP21-0020 are attached to this staff report and will be included with the action order, if approved.

The subject property is designated as High Density Rural (HDR). The proposed use of a private school (which is classified as “Education-Private School Facilities) use type is permissible in HDR with a special use permit per WCC Table 110.302.05.2. Therefore, the applicant is seeking approval of this SUP from the Board of Adjustment.

Additionally, Article 810, Special Use Permits, allows the Board of Adjustment to vary development code standards in conjunction with the approval process per WCC 110.810.20(e). The Board of Adjustment will be ruling on the requests to vary standards below:

Variance(s) Requested	Relevant Code
Remove all Landscape Requirements	WCC 110.412
Remove all Parking Requirements	WCC 110.410

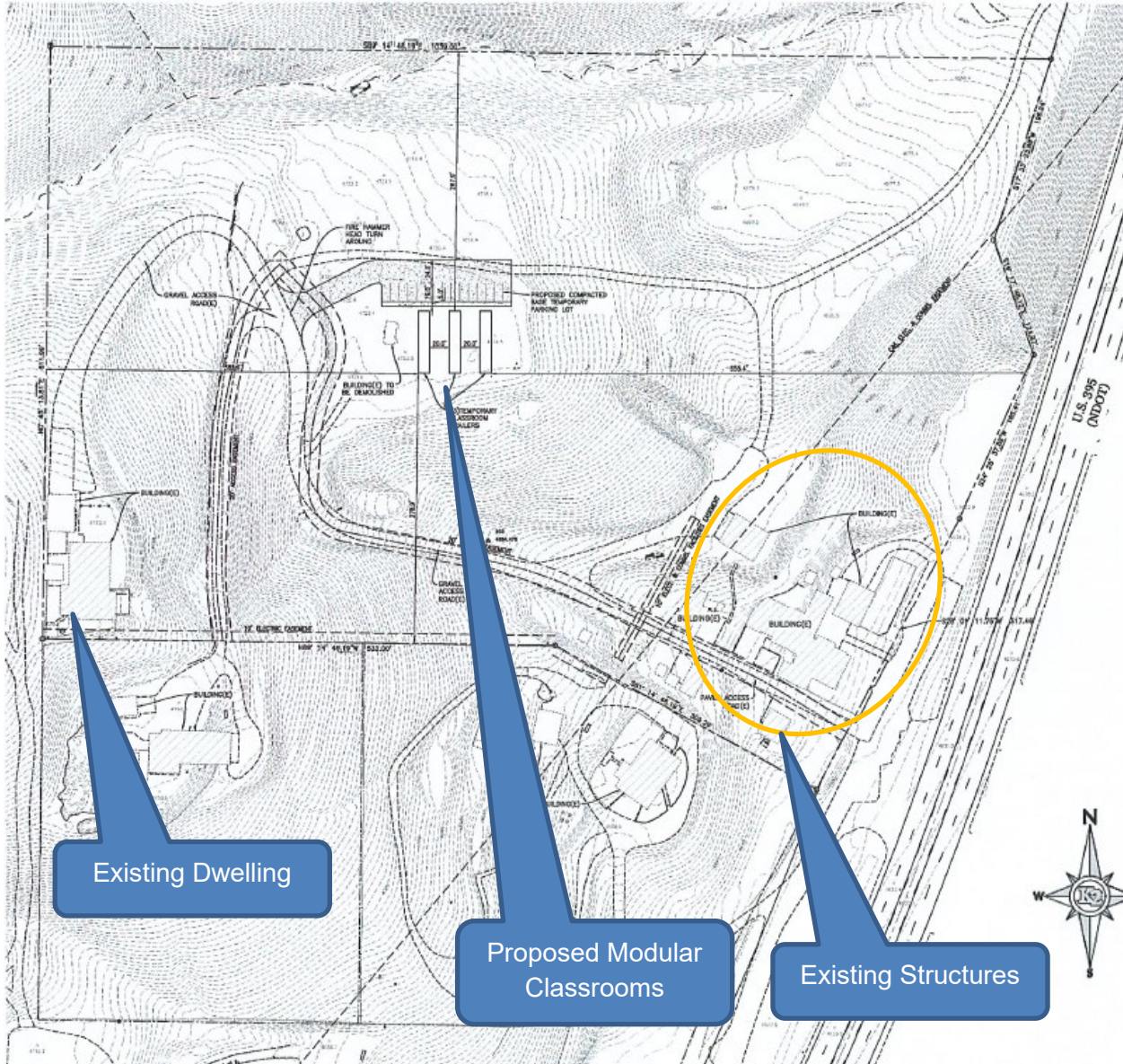

**Site Plan**



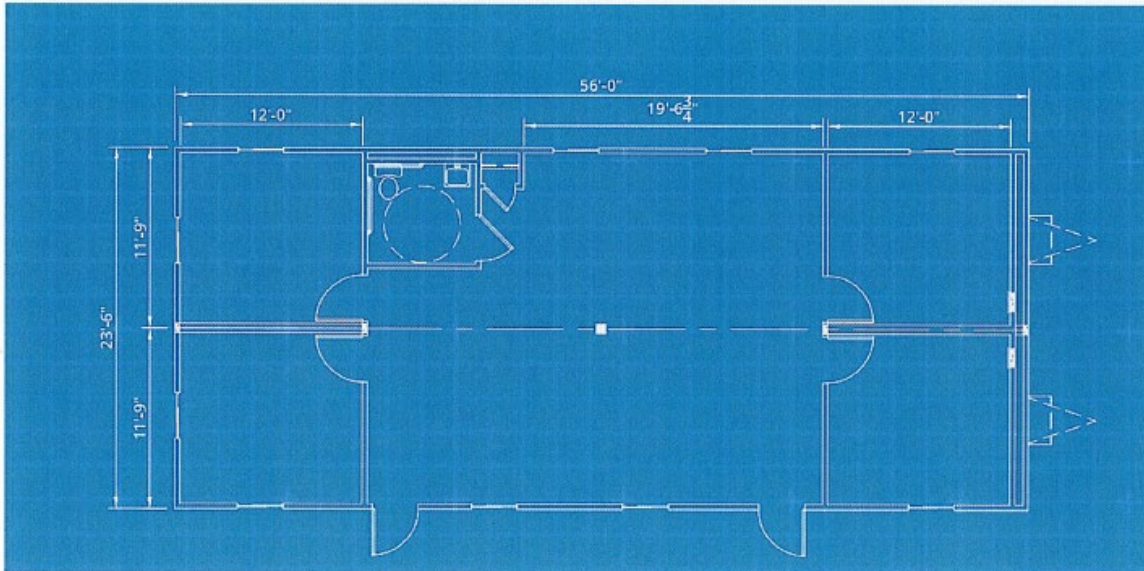

**Modular Building Elevation and Floor Plan**

**Project Evaluation**

The subject site consists of approximately 16 acres of land, on a hillside between US395 South and I 580, in the South Valleys Area Plan. The site includes several structures, area of previous disturbance and grading and some mature trees and vegetation. The site shows evidence of a long history of uses.

There are no valid land use entitlements on the subject site, at this time. The applicant has been using the site as a private school since 2017, according to the application materials. There is no valid Washoe County business license. At this time, the applicant seeks to legitimize the use as a private school and to allow the expansion of the school by means of installation of three modular classroom structures.

The school is proposed to accommodate a maximum of 100 students from kindergarten to 12<sup>th</sup> grade. The current enrollment is approximately 12 students.

The definition of Education – Private School Facility follows:

Education. Education use type refers to educational services provided by public, private or parochial institutions, but excludes uses classified under commercial education services. Typical uses include elementary, junior high, and senior high schools, and junior colleges. Curriculum must be approved by the State Department of Education. This use type does not refer to home schooling of children who live on-site.

- (1) Private School Facilities. Private School Facilities use type refers to educational services for the education of the children of the community that are funded primarily by means other than tax revenue.

The application materials refer to the proposed modular classroom structures as “temporary” classrooms and seek approval for a period of three years. The proposed modular classroom structures (which are approximately 24 feet by 56 feet in size, or approximately 1400 square feet each) are not temporary uses. Temporary uses are governed by Article 310 of the Washoe County Development Code and include uses such as circuses, carnivals, farmers markets, Christmas tree sales lots and similar uses. Such uses are generally of very short duration, measured in days or possibly a few weeks, but not in years, as requested by the applicant.

For this reason, staff has reviewed the request as permanent use. The site is generally suitable for the proposed use. Several existing structures have been refurbished and are generally attractive in appearance. There are few neighbors who would be impacted by the traffic and noise generated by the private school, and staff is generally inclined toward approval of the use. However, because the applicant has requested a permanent use, that being a private school, and as there are no existing land use entitlements, a recommendation of approval by staff is predicated upon the applicant bringing the existing structures, which are being used for the private school, into conformance with all generally applicable codes, as would be applied to any new civic or commercial use, prior to further operation of the school. Likewise, the installation of new modular buildings for classrooms, will require compliance with all current generally applicable codes.

Some of the applicable codes will require improvements such as installation of landscaping, paved parking areas and driveway areas, all exterior lighting must be down-shielded such that light is emitted earthward only, and disused sign structures on the subject site will be removed. While it is not strictly necessary to place conditions of approval on a special use permit to require code compliance, this situation is a bit unique as the facility has been used previously without appropriate approvals. For this reason, conditions that indicate some, but not necessarily all, of the relevant codes have been included with the recommendation as a courtesy to the applicant and to minimize misunderstanding when building permits are reviewed.

Again, because the use proposed is a permanent use, it is not appropriate to waive all parking and landscape standards, as the applicant has requested. Staff recommends that all generally applicable standards be applied to this use as would be applied to any other permanent civic or commercial use type. Staff recommends that the Board deny all parts of the requested variances to required standards.





**Overhead Photo of Subject Site**



**Photos of Subject Site**



**Area Plan Evaluation**

The subject parcel is located within the South Valleys Area Plan. The following is/are the pertinent policy(ies) from the Area Plan:

***Relevant Area Plan Policies Reviewed***

<b>Policy</b>	<b>Brief Policy Description</b>	<b>Complies</b>	<b>Condition of Approval</b>
<b>SV 2.3</b>	Site development plans in the South Valleys planning area must submit a plan for the control of noxious weeds. The plan should be developed through consultation with the Washoe County District Health Department, the University of Nevada Cooperative Extension, and/or the Washoe-Storey Conservation District. The control plan will be implemented on a voluntary compliance basis.		Condition to ensure compliance is included with the recommendation.
<b>SV 2.7</b>	Any lighting proposed must show how it is consistent with current Best Management Practices "dark-sky" standards. In subdivisions established after the date of final adoption of this Plan, the use of streetlights will be minimized.		Condition to ensure compliance is included with the recommendation.
<b>SV 2.8</b>	Street lights, security lights and other outdoor lighting should be powered by solar or other renewable energy sources whenever possible.		Condition to ensure compliance is included with the recommendation.
<b>SV 2.16</b>	The approval of all special use permits and administrative permits must include a finding that the community character as described in the Character Statement can be adequately conserved through mitigation of any identified potential negative impacts.	Yes	
<b>SV 5.2</b>	The review of all special use permits for the establishment of a non-residential use in Pleasant Valley must include a consideration of how the proposed use contributes to the desired community character as described in the character statement.	Yes	
<b>SV 10.1</b>	All development proposals must demonstrate how the established level of service on local transportation facilities will be maintained at the level determined to be acceptable by the Regional Transportation Commission (RTC).	Yes	
<b>SV12.2</b>	The Washoe County Departments of Community Development and Public Works will establish and oversee compliance and enforcement of design standards for grading that minimize the visual impact of all residential and non-residential hillside development, including road cuts and driveways.		Condition to ensure compliance is included with the recommendation.
<b>SV18.3</b>	The granting of special use permits in the South Valleys must be accompanied by a finding that no significant degradation of air quality will occur as a result of the permit. As necessary, conditions may be placed on special use permits to ensure no significant degradation of air quality will occur. The Department of Community Development will seek the advice and input of the Air Quality Division of the Department of Health in the implementation of this policy.	Yes	



<b>SV 19.1</b>	"Development proposals, with the exception of single family homes and uses accessory to single family homes, within the South Valleys planning area will include detailed soils and geo-technical studies sufficient to: a. Ensure structural integrity of roads and buildings. b. Provide adequate setbacks from potentially active faults or other hazards. c. Minimize erosion potential.		Condition to ensure compliance is included with the recommendation.
--------------------	---	--	---

### **Reviewing Agencies**

The following agencies/individuals received a copy of the project application for review and evaluation.

<b>Agency</b>	<b>Sent to Review</b>	<b>Responded</b>	<b>Provided Conditions</b>	<b>Contact</b>
Nevada Dept of Transportation	<input checked="" type="checkbox"/>	<input checked="" type="checkbox"/>	<input type="checkbox"/>	Alex Wolfson 775.834.8365
Nevada Dept of Env Protection	<input checked="" type="checkbox"/>	<input type="checkbox"/>	<input type="checkbox"/>	
Nevada Div. of Wildlife	<input checked="" type="checkbox"/>	<input type="checkbox"/>	<input type="checkbox"/>	
Washoe County Building & Safety	<input checked="" type="checkbox"/>	<input type="checkbox"/>	<input type="checkbox"/>	
Washoe County Parks & Open Spaces	<input checked="" type="checkbox"/>	<input checked="" type="checkbox"/>	<input type="checkbox"/>	Sophia Kirschenman 775.328.3623
Washoe County Water Rights	<input checked="" type="checkbox"/>	<input type="checkbox"/>	<input type="checkbox"/>	
Washoe County Engineering	<input checked="" type="checkbox"/>	<input checked="" type="checkbox"/>	<input type="checkbox"/>	Walter West 775.328.2041
Washoe County Sherriff	<input checked="" type="checkbox"/>	<input type="checkbox"/>	<input type="checkbox"/>	
WCHD – Air Quality	<input checked="" type="checkbox"/>	<input checked="" type="checkbox"/>	<input type="checkbox"/>	Genine Rosa 775.784.7204
WCHD – Environment Health	<input checked="" type="checkbox"/>	<input checked="" type="checkbox"/>	<input type="checkbox"/>	David Kelly 775.328.6176
WCHD- EMS	<input checked="" type="checkbox"/>	<input type="checkbox"/>	<input type="checkbox"/>	
Truckee Meadows Fire Protection District	<input checked="" type="checkbox"/>	<input checked="" type="checkbox"/>	<input type="checkbox"/>	Brittany Lemon 775.326.6079
RTC Washoe	<input checked="" type="checkbox"/>	<input checked="" type="checkbox"/>	<input type="checkbox"/>	Rebecca Kapular 775.348.0400
Washoe Storey Conservation District	<input checked="" type="checkbox"/>	<input checked="" type="checkbox"/>	<input type="checkbox"/>	Jim Shaffer 775.857.8500 x131
Washoe County School District	<input checked="" type="checkbox"/>	<input type="checkbox"/>	<input type="checkbox"/>	
Truckee Meadows Regional Planning	<input checked="" type="checkbox"/>	<input type="checkbox"/>	<input type="checkbox"/>	
Nevada Historic Preservation	<input checked="" type="checkbox"/>	<input type="checkbox"/>	<input type="checkbox"/>	

All conditions required by the contacted agencies can be found in Exhibit A, Conditions of Approval.

### **Staff Comment on Required Findings**

WCC Section 110.810.30, Article 810, *Special Use Permits*, requires that all the following findings be made to the satisfaction of the Washoe County Board of Adjustment before granting approval of the request. Staff has completed an analysis of the special use permit application and has determined that the proposal is in compliance with the required findings as follows.

1. Consistency. That the proposed use is consistent with the action programs, policies, standards and maps of the Master Plan and the South Valleys Area Plan.

Staff Comment: *There are no action programs, policies, standards and maps of the Master Plan and the South Valleys Area Plan that prohibit the establishment of a private school.*

2. Improvements. That adequate utilities, roadway improvements, sanitation, water supply, drainage, and other necessary facilities have been provided, the proposed improvements are properly related to existing and proposed roadways, and an adequate public facilities determination has been made in accordance with Division Seven.

*Staff Comment: All relevant agencies have reviewed the application and no recommendation for denial have been received therefore, adequate utilities, roadway improvements, sanitation, water supply, drainage, and other necessary facilities have been provided, the proposed improvements are properly related to existing and proposed roadways, and an adequate public facilities determination has been made in accordance with Division Seven*

3. Site Suitability. That the site is physically suitable for a private school, and for the intensity of such a development.

*Staff Comment: The site shows evidence of a variety of historic uses. The current use will require all facilities and buildings to be improved to meet current Codes in all respects.*

4. Issuance Not Detrimental. That issuance of the permit will not be significantly detrimental to the public health, safety or welfare; injurious to the property or improvements of adjacent properties; or detrimental to the character of the surrounding area.

*Staff Comment: As the site has been utilized for similar businesses in the past, and as there are few adjacent residences, issuance of the permit will not be significantly detrimental to the public health, safety or welfare; injurious to the property or improvements of adjacent properties; or detrimental to the character of the surrounding area.*

5. Effect on a Military Installation. Issuance of the permit will not have a detrimental effect on the location, purpose or mission of the military installation.

*Staff Comment: There is no military installation within the area required to be noticed for this permit, therefore there can be no detrimental effect.*

6. The community character as described in the Character Statement can be adequately conserved through mitigation of any identified potential negative impacts.

*Staff Comment: There are no provisions of the Character Statement that are particularly applicable to the use of the historic facility and buildings as a private school. Any potential negative impacts will be mitigated by adherence to generally applicable Code provisions that mitigate impacts upon the surrounding area.*

7. No significant degradation of air quality will occur as a result of the permit.

*Staff Comment: The Air Quality Management Division of the District Health Department was given the opportunity to comment on the project and did not recommend denial.*

## **Recommendation**

After a thorough analysis and review, Special Use Permit Case Number WSUP21-0020 is being recommended for approval with conditions. Staff offers the following motion for the Board's consideration.

## **Motion**

I move that, after giving reasoned consideration to the information contained in the staff report and information received during the public hearing, the Washoe County Board of Adjustment approve Special Use Permit Case Number WSUP21-0020 for St. Nicholas Orthodox Academy, with the conditions included as Exhibit A to this matter, and does not vary any generally applicable development standards, having made all five findings in accordance with Washoe County Code Section 110.810.30:

1. Consistency. That the proposed use is consistent with the action programs, policies, standards and maps of the Master Plan and the South Valleys Area Plan;

2. Improvements. That adequate utilities, roadway improvements, sanitation, water supply, drainage, and other necessary facilities have been provided, the proposed improvements are properly related to existing and proposed roadways, and an adequate public facilities determination has been made in accordance with Division Seven;
3. Site Suitability. That the site is physically suitable for private school, and for the intensity of such a development;
4. Issuance Not Detrimental. That issuance of the permit will not be significantly detrimental to the public health, safety or welfare; injurious to the property or improvements of adjacent properties; or detrimental to the character of the surrounding area; and
5. Effect on a Military Installation. Issuance of the permit will not have a detrimental effect on the location, purpose or mission of the military installation.
6. The community character as described in the Character Statement can be adequately conserved through mitigation of any identified potential negative impacts.
7. No significant degradation of air quality will occur as a result of the permit.

**Appeal Process**

Board of Adjustment action will be effective 10 calendar days after the written decision is filed with the Secretary to the Board of Adjustment and mailed to the applicant, unless the action is appealed to the Washoe County Board of County Commissioners, in which case the outcome of the appeal shall be determined by the Washoe County Board of County Commissioners. Any appeal must be filed in writing with the Planning and Building Division within 10 calendar days from the date the written decision is filed with the Secretary to the Board of Adjustment and mailed to the applicant.

Applicant: St. Nicholas Orthodox Academy  
 Attn: Janet Cummings  
 16255 S. Virginia Street  
 Reno, NV 89521  
 Email: drjanetcummings@me.com

Owner: JLC Realty, LLC  
 Attn: Janet Cummings  
 4781 Caughlin Parkway  
 Reno, NV 89519  
 Email: drjanetcummings@me.com

Representatives: Christy Corp.  
 Attn: Mike Railey  
 1000 Kiley Pkwy  
 Sparks, NV 89436  
  
 K2 Engineering  
 Attn: Brandt Kennedy  
 860 Maestro Drive, Suite A  
 Reno, NV 89511



# Conditions of Approval

Special Use Permit Case Number WSUP21-0020

The project approved under Special Use Permit Case Number WSUP21-0020 shall be carried out in accordance with the conditions of approval granted by the Board of Adjustment on September 2, 2021. Conditions of approval are requirements placed on a permit or development by each reviewing agency. These conditions of approval may require submittal of documents, applications, fees, inspections, amendments to plans, and more. These conditions do not relieve the applicant of the obligation to obtain any other approvals and licenses from relevant authorities required under any other act.

**Unless otherwise specified**, all conditions related to the approval of this special use permit shall be met or financial assurance must be provided to satisfy the conditions of approval prior to issuance of a grading or building permit. The agency responsible for determining compliance with a specific condition shall determine whether the condition must be fully completed or whether the applicant shall be offered the option of providing financial assurance. All agreements, easements, or other documentation required by these conditions shall have a copy filed with the County Engineer and the Planning and Building Division.

Compliance with the conditions of approval related to this special use permit is the responsibility of the applicant, his/her successor in interest, and all owners, assignees, and occupants of the property and their successors in interest. Failure to comply with any of the conditions imposed in the approval of the special use permit may result in the institution of revocation procedures.

Washoe County reserves the right to review and revise the conditions of approval related to this Special Use Permit should it be determined that a subsequent license or permit issued by Washoe County violates the intent of this approval.

For the purpose of conditions imposed by Washoe County, “may” is permissive and “shall” or “must” is mandatory.

Conditions of approval are usually complied with at different stages of the proposed project. Those stages are typically:

- Prior to permit issuance (i.e., grading permits, building permits, etc.).
- Prior to obtaining a final inspection and/or a certificate of occupancy.
- Prior to the issuance of a business license or other permits/licenses.
- Some “conditions of approval” are referred to as “operational conditions.” These conditions must be continually complied with for the life of the project or business.

**The Washoe County Commission oversees many of the reviewing agencies/departments with the exception of the following agencies.**

- **The DISTRICT BOARD OF HEALTH, through the Washoe County Health District, has jurisdiction over all public health matters in the Health District. Any conditions set by the Health District must be appealed to the District Board of Health.**



FOLLOWING ARE CONDITIONS OF APPROVAL REQUIRED BY THE REVIEWING AGENCIES. EACH CONDITION MUST BE MET TO THE SATISFACTION OF THE ISSUING AGENCY.

**Washoe County Planning and Building Division**

1. The following conditions are requirements of Planning and Building, which shall be responsible for determining compliance with these conditions.

**Contact Name – Roger Pelham, 775.328.3622, rpelham@washoecounty.us**

- a. **The applicant shall attach a copy of the action order approving this project to all permits and applications (including building permits) applied for as part of this special use permit.**
- b. The applicant shall demonstrate substantial conformance to the plans approved as part of this special use permit. The Planning and Building Division shall determine compliance with this condition.
- c. A maximum of 100 students are permitted.
- d. The applicant shall submit construction plans, with all information necessary for comprehensive review by Washoe County, and initial building permits shall be issued within two years from the date of approval by Washoe County. The applicant shall complete construction within the time specified by the building permits. Compliance with this condition shall be determined by the Planning and Building Division.
- e. A note shall be placed on all construction drawings and grading plans stating:

NOTE

Should any cairn or grave of a Native American be discovered during site development, work shall temporarily be halted at the specific site and the Sheriff's Office as well as the State Historic Preservation Office of the Department of Conservation and Natural Resources shall be immediately notified per NRS 383.170.

- f. The applicant shall provide written approval from the Nevada Department of Transportation for all proposed work within NDOT right-of-way. That approval shall be included with any application for a building permit.
- g. The applicant shall obtain a Washoe County business license for the private school, prior to commencement of any private school activities on the subject site.
- h. The applicant shall bring all existing structures up to current Code in all respects.
- i. The applicant shall comply with all generally applicable Codes and ordinances for all existing and proposed buildings and structures.
- j. The applicant shall comply with all generally applicable Codes for the existing and proposed buildings and structures, including but not limited to Article 410, Parking and Loading, Article 412, Landscaping, Article 414, Noise and Lighting and Article 505, Signs.
- k. All disturbed areas on the subject site, that are not permanently stabilized by a building, pavement or formal landscaping shall be re-vegetated with a native seed mix.

- I. The previously-graded "borrow pit" area, shown as point "A" on the following graphic, shall be filled in or re-graded such that the slope is restored to a condition that mimics its original, undisturbed condition.



- m. The applicant shall remove all existing disused sign structures from the subject site.
- n. Any new signage shall comply with all applicable aspects of Section 500 of the Washoe County Development Code.
- o. The development plans shall include a plan for the control of noxious weeds. The plan should be developed through consultation with the Washoe County District Health Department, the University of Nevada Cooperative Extension, and/or the Washoe-Storey Conservation District
- p. The development plans shall demonstrate consistency with current best management practices regarding "dark-sky" standards. All exterior lighting shall be down-shielded such that light is emitted earthward only.
- q. Street lights, security lights and other outdoor lighting should be powered by solar or other renewable energy sources whenever possible.
- r. The design of all grading shall minimize the visual impact of hillside development, including road cuts and driveways.
- s. The development plans shall include detailed soils and geo-technical studies sufficient to:
  - i. Ensure structural integrity of roads and buildings.
  - ii. Provide adequate setbacks from potentially active faults or other hazards.
  - iii. Minimize erosion potential.
- t. The following **Operational Conditions** shall be required for the life of the business:
  - i. This special use permit shall remain in effect until or unless it is revoked or is inactive for one year.
  - ii. Failure to comply with any of the conditions of approval shall render this approval out of conformance and subject to revocation.

- iii. The applicant and any successors shall direct any potential purchaser/operator of the site and/or the administrative permit to meet with Planning and Building to review conditions of approval prior to the final sale of the site and/or the administrative permit. Any subsequent purchaser/operator of the site and/or the administrative permit shall notify Planning and Building of the name, address, telephone number, and contact person of the new purchaser/operator within 30 days of the final sale.
- iv. This special use permit shall remain in effect as long as the business is in operation and maintains a valid business license.

### **Washoe County Health District**

2. The following conditions are requirements of the Washoe County Health District, which shall be responsible for determining compliance with these conditions.

**Contact Name – Genine Rosa, 775.784.7204, grosa@washocounty.us**

- a. Dust Control Permit will be required prior to breaking ground, failure to do so may result in enforcement action resulting in a Notice of Violation with associated fines.

### **Truckee Meadows Fire Protection District**

3. The following conditions are requirements of the Truckee Meadows Fire Protection District, which shall be responsible for determining compliance with these conditions.

**Contact Name – Brittany Lemon, 775.326.6079, blemon@tmfpd.us**

- a. This project shall meet and comply with all requirements of currently adopted TMFPD fire codes, ordinances, and standards at the time of construction to include infrastructure for fire apparatus, access roads and water supply (<https://tmfpd.us/fire-code/>).

### **Washoe County Engineering and Capital Projects**

4. The following conditions are requirements of the Engineering Division, which shall be responsible for determining compliance with these conditions.

**Contact Name – Robert Wimer, 775.328.2059, rwimer@washocounty.us**

- a. A complete set of construction improvement drawings, including an on-site grading plan, shall be submitted when applying for a building/grading permit. Grading shall comply with best management practices (BMP's) and shall include detailed plans for grading, site drainage, erosion control (including BMP locations and installation details), slope stabilization, and mosquito abatement. Placement or removal of any excavated materials shall be indicated on the grading plan. Silts shall be controlled on-site and not allowed onto adjacent property.
- b. For construction areas larger than 1 acre, the developer shall obtain from the Nevada Division of Environmental Protection a Stormwater Discharge Permit or Waiver for construction and submit a copy to the Engineering Division prior to issuance of a grading permit.
- c. The developer shall complete and submit the Construction Permit Submittal Checklist and pay the Construction Stormwater Inspection Fee prior to obtaining a grading permit. The County Engineer shall determine compliance with this condition.
- d. If over 1 acre of disturbance, a grading bond of \$2,000/acre of disturbed area shall be provided to the Engineering Division prior to any grading.

- e. All disturbed areas left undeveloped for more than 30 days shall be treated with a dust palliative. Disturbed areas left undeveloped for more than 45 days shall be revegetated. Methods and seed mix must be approved by the County Engineer with technical assistance from the Washoe-Storey Conservation District. The applicant shall submit a revegetation plan to the Washoe-Storey Conservation District for review.

\*\*\* End of Conditions \*\*\*



**From:** [Rosa, Genine](#)  
**To:** [Pelham, Roger](#)  
**Subject:** Third Review of Applications Submitted July 2021  
**Date:** Tuesday, July 20, 2021 4:53:26 PM

**Special Use Permit Case Number WSUP21-0020 (St Nicholas Academy)** –  
Dust Control Permit will be required prior to breaking ground, failure to do so may result in enforcement action resulting in a Notice of Violation with associated fines. For Dust Control Permit questions call AQMD at 775-784-7200 or visit [www.OurCleanAir.com](http://www.OurCleanAir.com).  
Link to application: [Dust Control Permit Application](#)

P.S. – Please be sure to click the link below and sign up to receive air quality news, updates, public notices and more via e-mail.

**Genine Rosa**

Environmental Engineer II | Air Quality Management Division | Washoe County Health District  
[grosa@washoecounty.us](mailto:grosa@washoecounty.us) | O: (775) 784-7204 | 1001 E. Ninth St., Bldg. B, Reno, NV 89512

\*My schedule is 4 x 10's M-Th 7-5:30 off on Fridays.

[www.OurCleanAir.com](http://www.OurCleanAir.com) | [Subscribe to get Air Quality Updates!](#)



Please take our customer satisfaction survey by clicking [here](#)

**WASHOE COUNTY  
HEALTH DISTRICT**

ENHANCING QUALITY OF LIFE

July 16, 2021

Washoe County Community Services  
Planning and Development Division  
PO Box 11130  
Reno, NV 89520-0027

RE: St Nicholas Orthodox Academy; 045-210-01  
Special Use Permit; WSUP21-0020

Dear Washoe County Staff:

The following conditions are requirements of the Washoe County Health District, Environmental Health Division (EHS), which shall be responsible for determining compliance with these conditions.

- a) EHS has no issues with the special use permit as proposed. The school operation is currently permitted by EHS.
- b) As proposed, the operation will still fall under the threshold of a public water system but in the event that the population served increases, a public water system permit will be required from NDEP Bureau of Safe Drinking Water.

If you have any questions or would like clarification regarding the foregoing, please contact David Kelly regarding all EHS comments.

Sincerely,



David Kelly  
EHS Supervisor  
Environmental Health Services  
Washoe County Health District

ENVIRONMENTAL HEALTH SERVICES  
1001 East Ninth Street | P.O. Box 11130 | Reno, Nevada 89520  
775-328-2434 | Fax: 775-328-6176 | [washoecounty.us/health](http://washoecounty.us/health)  
Serving Reno, Sparks and all of Washoe County, Nevada | Washoe County is an Equal Opportunity Employer



**From:** [Lemon, Brittany](#)  
**To:** [Pelham, Roger](#)  
**Cc:** [Way, Dale](#)  
**Subject:** WSUP21-0020 (St Nicholas Academy)  
**Date:** Wednesday, July 21, 2021 8:42:40 AM  
**Attachments:** [image001.png](#)

---

Good Morning Roger,

This project shall meet and comply with all requirements of currently adopted TMFPD fire codes, ordinances, and standards at the time of construction to include infrastructure for fire apparatus access roads and water supply.

<https://tmfpd.us/fire-code/>

Thank you!

**Brittany Lemon**

**Fire Captain - Fire Prevention | Truckee Meadows Fire & Rescue**

[blemon@tmfpd.us](mailto:blemon@tmfpd.us) | Office: 775.326.6079 | Cell: 775.379.0584

3663 Barron Way, Reno, NV 89511



*"Committed to excellence, service, and the protection of life and property in our community"*



STEVE SISOLAK  
Governor

STATE OF NEVADA  
DEPARTMENT OF TRANSPORTATION  
1263 S. Stewart Street  
Carson City, Nevada 89712

KRISTINA L. SWALLOW, P.E., Director

July 26, 2021

Washoe County Community Services Department  
Planning and Building Division  
1001 East 9<sup>th</sup> Street  
Reno, NV 89512  
Attention: Roger Pelham, Senior Planner

SENT VIA ELECTRONIC MAIL

RE: WSUP21-0020 (St Nicholas Academy)

Dear Mr. Pelham,

Nevada Department of Transportation (NDOT) District II staff has reviewed the following application and provided comments accordingly:

**Special Use Permit Case Number WSUP21-0020 (St Nicholas Academy)** – For hearing, discussion, and possible action to approve the establishment of a private school including three temporary modular classroom buildings.

**NDOT comments:**

1. The site is located directly adjacent and has access to South Virginia Street. South Virginia St is an NDOT owned road that is officially designated as US-395 Alternate (US-395 ALT) and functionally classified as an urban minor arterial.
2. NDOT only allows the use of permitted accesses to the state highway system. This includes existing accesses that are going to be redeveloped or have had a change in ownership. While not necessarily a requirement of this special use permit request, the applicant will be required to obtain an NDOT occupancy permit for access as part of this application or the eventual "phase 2" special use permit application.
3. All work proposed within or adjacent to the US-395 ALT right of way must comply with NDOT's Standard Plans, Access Management System and Standards, Terms and Conditions Relating to Right-of-Way Occupancy Permits, and Drainage Manual current version at the time of application. Please contact the NDOT District II Permits Office at (775) 834-8330 for information about obtaining NDOT occupancy permits.
4. The State defers to municipal government for land use development decisions. Public involvement for community development related improvements within or adjacent to NDOT right of way should be considered during the municipal land use development process. Significant improvements proposed within NDOT right of way may require additional public involvement. It is the responsibility of the applicant to perform such



additional public involvement.

5. This letter does not provide for approval or disapproval of any improvements proposed by the project. NDOT review during the occupancy permit process may result in modification to the proposed improvements or denial.

Thank you for the opportunity to review this request. NDOT reserves the right to incorporate further changes as this project progresses. Should you have any questions, please contact me at (775) 834-8365.

Sincerely,

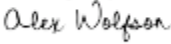
DocuSigned by:  
  
8D80C58A93244A2

Alex Wolfson, P.E., PTOE  
Engineering Manager

Cc: Rebecca Kapuler – Regional Transportation Commission  
Dale Keller – Regional Transportation Commission  
Sondra Rosenberg – NDOT Assistant Director of Planning  
Mike Fuess – NDOT District Engineer  
Rod Schilling – NDOT Traffic Operations  
File



**REGIONAL TRANSPORTATION COMMISSION**

*Metropolitan Planning • Public Transportation & Operations • Engineering & Construction*

Metropolitan Planning Organization of Washoe County, Nevada

July 21, 2021

FR: Chrono/PL 181-21

Mr. Chris Bronczyk, Planner  
Community Services Department  
Washoe County  
PO Box 11130  
Reno, NV 89520

Dear Mr. Bronczyk,

RE: WSUP21-0020 (St. Nicholas Academy)

The Regional Transportation Commission (RTC) has reviewed this application to approve the establishment of a private school including three temporary modular classroom buildings.

The project site access is located on a Nevada Department of Transportation (NDOT) facility and it is recommended that project access and improvements meet current NDOT standards. Recommend applicant work with NDOT District 2 staff to determine current and future project related improvements to US 395 (South Virginia Street).

The RTP, RTC Bicycle/Pedestrian Master Plan and the Nevada Department of Transportation Pedestrian Safety Action Plan, all indicate that new development and re-development will be encouraged to construct pedestrian and bicycle facilities, internal and/or adjacent to the development, within the regional road system. In addition, these plans recommend that the applicant be required to design and construct any sidewalks along the frontage of the property in conformance with the stated ADA specifications.

Thank you for the opportunity to comment on this application. Please feel free to contact me at 775-332-0174 or email me at [rkapuler@rtcwashoe.com](mailto:rkapuler@rtcwashoe.com) if, you have any questions or comments.

Sincerely,

Rebecca Kapuler  
Senior Planner

CC: Alex Wolfson, NDOT District  
Dale Keller, Regional Transportation Commission  
Blaine Petersen, Regional Transportation Commission,  
Sara Going, Regional Transportation Commission  
Tina Wu, Regional Transportation Commission  
Andrew Jankayura, Regional Transportation Commission  
Scott Miklos, Regional Transportation Commission

/St. Nicholas Academy

**From:** [Kirschenman, Sophia](#)  
**To:** [Pelham, Roger](#)  
**Subject:** Parks Comments Re: WSUP21-0020  
**Date:** Monday, July 19, 2021 10:41:25 AM  
**Attachments:** [Outlook-xnplrpyr.png](#)  
[Outlook-onrmu0qq.png](#)  
[Outlook-iirqe0ed.png](#)  
[Outlook-1bgbeowo.png](#)  
[Outlook-dw1nxyt.png](#)

---

Hi Roger,

I've reviewed WSUP21-0020 (St. Nicholas Academy) on behalf of Washoe County Regional Parks and Open Space and have no comments or conditions.

Thank you,



Sophia Kirschenman

Park Planner | Community Services Department

775.328.3623 | 1001 E. 9th Street, Reno, NV 89512



Tell us how we did by taking a quick [survey](#).

Please consider the environment before printing this e-mail.



**WASHOE COUNTY**  
**COMMUNITY SERVICES**  
INTEGRITY COMMUNICATION SERVICE

P.O. Box 11130  
Reno, Nevada 89520-0027  
Phone: (775) 328-3600  
Fax: (775) 328-3699

July 15, 2021

TO: Roger Pelham, Senior Planner, CSD, Planning & Development Division  
FROM: Vahid Behmaram, Water Management Planner Coordinator, CSD  
SUBJECT: Special Use Permit Case Number WSUP21-0020 (St Nicholas Academy)

**Project description:**

The applicant is proposing to approve the establishment of a private school including three temporary modular classroom buildings.

Location: 16255 South Virginia St. Assessor's Parcel Number: 045-210-01.

*The Community Services Department (CSD) recommends approval of this project with the following Water Rights conditions:*

**Comments:** The application indicates water supply is from an onsite well. State of Nevada Division of Water Resources water rights database indicates Permit # 65090, Certificate # 18936 appurtenant to this parcel of land. Said water rights are in the ownership of the applicants to this application and have a duty of 4.00 acre-feet per year. The application also indicates that:

Currently, St. Nicholas has an enrollment of 10 to 12 students with 4 full-time and 1 half-time teachers. With the addition of the temporary classrooms, enrollment could slightly increase but no more than 15 students are anticipated. With such a small number of students and employees, allowing the temporary classrooms now will not result in any negative impacts to surrounding properties and simply permits the school to continue to operate at the site as it has since late 2017.

***Conditions:***

The applicant shall provide historical well pumpage data which indicates current annual water consumption which in turn will determine if there is sufficient water rights remaining to support the proposed expansion. If the above data indicates the need for additional water rights, then the applicant shall acquire and transfer additional ground water right to the well associated with this project.

IT IS OF EXETREM IMPORTANCE TO OBTAIN WASHOE COUNTY DISTRICT HEALTH CONDITIONS OF APPROVAL REGARSD THE PROPOSED PROJECT AS THE





**WASHOE COUNTY**  
**COMMUNITY SERVICES**  
INTEGRITY COMMUNICATION SERVICE

P.O. Box 11130  
Reno, Nevada 89520-0027  
Phone: (775) 328-3600  
Fax: (775) 328-3699

**PROPOSED EXPANSION MIGHT CAUSE THE WATER SYSTEM TO BE CONSIDERED  
AS A REGULATED PUBLIC WATER SYSTEM.**







Washoe-Storey Conservation District

Bret Tyler Chairmen  
Jim Shaffer Treasurer  
Cathy Canfield Storey app  
Jean Herman Washoe app

1365 Corporate Blvd.  
Reno NV 89502  
775 857-8500 ext. 131  
nevadaconservation.com

July 27, 2021

Washoe County Community Services Department

C/O Roger Pelham, Senior Planner

1001 E Ninth Street, Bldg. A

Reno, NV 89512

Re: WSUP21-0020 St. Nicholas Academy

Dear Roger,

In reviewing the special use permit for three temporary modular buildings, the Conservation District has the following comment.

We recommend as a condition of approval, if possible, the modular buildings color reflect the natural landscape even though there are no visual impacts to adjoining properties.

Thank you for providing us the opportunity to review the project that may have impacts on our natural resources and if there are any questions call us at (775) 750-8272.

Sincerely,

Shaffer-Tyler



**WASHOE COUNTY**  
COMMUNITY SERVICES DEPARTMENT  
Engineering and Capital Projects

1001 EAST 9<sup>TH</sup> STREET  
RENO, NEVADA 89512  
PHONE (775) 328-3600  
FAX (775) 328.3699

Date: July 28, 2021

To: Roger Pelham, Planner

From: Robert Wimer, P.E., Licensed Engineer

Re: Special Use Permit for *St. Nicholas Academy WSUP21-0020*  
APN 045-210-01

**GENERAL PROJECT DISCUSSION**

Washoe County Engineering staff has reviewed the above referenced application. The Special Use Permit is for the construction of three temporary classroom buildings for a private school and is located on approximately 13.96 acres at the west side of South Virginia Street, south of Rhodes Road and north of Cheyenne Drive. The Engineering and Capital Projects Division recommends approval with the following comments and conditions of approval which supplement applicable County Code and are based upon our review of the site and the application prepared by Christy Corporation. The County Engineer shall determine compliance with the following conditions of approval.

For questions related to sections below, please see the [contact](#) name provided.

**GENERAL CONDITIONS**

Contact Information: Robert Wimer, P.E. (775) 328-2059

1. A complete set of construction improvement drawings, including an on-site grading plan, shall be submitted when applying for a building/grading permit. Grading shall comply with best management practices (BMP's) and shall include detailed plans for grading, site drainage, erosion control (including BMP locations and installation details), slope stabilization, and mosquito abatement. Placement or removal of any excavated materials shall be indicated on the grading plan. Silts shall be controlled on-site and not allowed onto adjacent property.
2. For construction areas larger than 1 acre, the developer shall obtain from the Nevada Division of Environmental Protection a Stormwater Discharge Permit or Waiver for construction and submit a copy to the Engineering Division prior to issuance of a grading permit.
3. The developer shall complete and submit the Construction Permit Submittal Checklist and pay the Construction Stormwater Inspection Fee prior to obtaining a grading permit. The County Engineer shall determine compliance with this condition.
4. If over 1 acre of disturbance, a grading bond of \$2,000/acre of disturbed area shall be provided to the Engineering Division prior to any grading.



Subject: *St. Nicholas Academy WSUP21-0020*  
Date: July 28, 2021  
Page: 2

5. All disturbed areas left undeveloped for more than 30 days shall be treated with a dust palliative. Disturbed areas left undeveloped for more than 45 days shall be revegetated. Methods and seed mix must be approved by the County Engineer with technical assistance from the Washoe-Storey Conservation District. The applicant shall submit a revegetation plan to the Washoe-Storey Conservation District for review.

**DRAINAGE (COUNTY CODE 110.416, 110.420, and 110.421)**

Contact Information: Robert Wimer, P.E. (775) 328-2059

No comments or conditions.

**TRAFFIC AND ROADWAY (COUNTY CODE 110.436)**

Contact Information: Mitch [Fink](#), (775) 328-2050

No comments or conditions.

**UTILITIES (County Code 422 & Sewer Ordinance)**

Contact Information: Tim Simpson, P.E. (775) 954-4648

No comments or conditions.

**From:** [Program, EMS](#)  
**To:** [Pelham, Roger](#); [Bronczyk, Christopher](#)  
**Cc:** [Lawson, Jacqueline](#); [Aaron Abbott](#)  
**Subject:** FW: July Agency Review Memo III  
**Date:** Thursday, July 29, 2021 3:05:38 PM  
**Attachments:** [July Agency Review Memo III.pdf](#)  
[image001.png](#)  
[image002.png](#)

---

Good afternoon,

The EMS Oversight Program and REMSA have reviewed item #1 and #4 of July Agency Review Memo III and we have no comments on these projects.

Thank you,

*Julie*

**Julie D Hunter, M.S.**

EMS Coordinator | Division of Epidemiology and Public Health Preparedness | Washoe County Health District  
[jdhunter@washoecounty.us](mailto:jdhunter@washoecounty.us) | O: (775) 326-6043 C: (775) 343-2143 | 1001 E. Ninth St., Bldg. B, Reno, NV 89512



Please take our customer satisfaction survey by clicking [here](#)

## Washoe County Development Application

Your entire application is a public record. If you have a concern about releasing personal information, please contact Planning and Building staff at 775.328.6100.

<b>Project Information</b>		Staff Assigned Case No.: _____	
Project Name: <b>St. Nicholas Orthodox Academy</b>			
Project Description: A SUP to allow for the establishment of a private school in the HDR zone and allow for 3 temporary classroom buildings. Refer to attached report for additional details.			
Project Address: 16255 South Virginia Street, Reno, NV 89521			
Project Area (acres or square feet): 13.96 acres			
Project Location (with point of reference to major cross streets <b>AND</b> area locator): The site is located on the west side of South Virginia Street (Old US 395), south of Rhodes Road, north of Cheyenne Drive.			
Assessor's Parcel No.(s):	Parcel Acreage:	Assessor's Parcel No.(s):	Parcel Acreage:
045-210-01	13.96 acres		
Indicate any previous Washoe County approvals associated with this application: Case No.(s).			
<b>Applicant Information</b> (attach additional sheets if necessary)			
<b>Property Owner:</b>		<b>Professional Consultant:</b>	
Name: JLC Realty, LLC		Name: Christy Corporation, Ltd.	
Address: 4781 Caughlin Pkwy.		Address: 1000 Kiley Pkwy.	
Reno, NV	Zip: 89519	Sparks, NV	Zip: 89436
Phone: (775) 848-3677	Fax:	Phone: (775) 502-8552	Fax:
Email: drjanetcummings@me.com		Email: mike@christynv.com	
Cell: (775) 848-3677	Other:	Cell: (775) 250-3455	Other:
Contact Person: Janet Cummings		Contact Person: Mike Railey	
<b>Applicant/Developer:</b>		<b>Other Persons to be Contacted:</b>	
Name: St. Nicholas Orthodox Academy		Name: K2 Engineering and Structural Design	
Address: 16255 S. Virginia St.		Address: 860 Maestro Dr., Suite A	
Reno, NV	Zip: 89521	Reno, NV	Zip: 89511
Phone: (775) 544-5565	Fax:	Phone: (775) 355-0505	Fax:
Email: drjanetcummings@me.com		Email: brandt@k2eng.net	
Cell: (775) 848-3677	Other:	Cell: (775) 560-8189	Other:
Contact Person: Janet Cummings		Contact Person: Brandt Kennedy, P.E.	
<b>For Office Use Only</b>			
Date Received:	Initial:	Planning Area:	
County Commission District:		Master Plan Designation(s):	
CAB(s):		Regulatory Zoning(s):	





Community Services Department

Planning and Building

**SPECIAL USE PERMIT**

(see page 7)

**SPECIAL USE PERMIT FOR GRADING**

(see page 9)

**SPECIAL USE PERMIT FOR STABLES**

(see page 12)

**APPLICATION**



Community Services Department  
Planning and Building  
1001 E. Ninth St., Bldg. A  
Reno, NV 89512-2845

Telephone: 775.328.6100

# Special Use Permit Application Supplemental Information

(All required information may be separately attached)

1. What is the project being requested?

This SUP would allow for the establishment of a private school use in the HDR zone zone along with 3 temporary modular buildings (6 classrooms) for no more than 3 years. Refer to attached report for a detailed description.

2. Provide a site plan with all existing and proposed structures (e.g. new structures, roadway improvements, utilities, sanitation, water supply, drainage, parking, signs, etc.)

Refer to attached plan.

3. What is the intended phasing schedule for the construction and completion of the project?

The 3 temporary buildings (6 classrooms) will be located onsite by the fall of 2021 and will be replaced with a new school facility within 3 years (subject to a new SUP). Refer to attached report for a detailed description.

4. What physical characteristics of your location and/or premises are especially suited to deal with the impacts and the intensity of your proposed use?

The proposed use is low intensity and the area where temporary classrooms are located has been previously graded. Refer to attached report for a detailed analysis.

5. What are the anticipated beneficial aspects or affects your project will have on adjacent properties and the community?

The project will provide for a schooling alternative for area youth and will ultimately include renovations and improvements to the existing site. Refer to attached report for additional details.

6. What are the anticipated negative impacts or affect your project will have on adjacent properties? How will you mitigate these impacts?

The project is a low impact use that is not expected to generate any negative impacts to surrounding properties. Refer to attached report for a detailed analysis.

7. Provide specific information on landscaping, parking, type of signs and lighting, and all other code requirements pertinent to the type of use being purposed. Show and indicate these requirements on submitted drawings with the application.

The buildings proposed with this initial phase will be temporary. As such, it requested to utilize all-weather surface and waive landscape requirements.

8. Are there any restrictive covenants, recorded conditions, or deed restrictions (CC&Rs) that apply to the area subject to the special use permit request? (If so, please attach a copy.)

<input type="checkbox"/> Yes	<input checked="" type="checkbox"/> No
------------------------------	--

9. Utilities:

a. Sewer Service	Septic (temprary classrooms are self-contained)
b. Electrical Service	NV Energy
c. Telephone Service	AT&T or Charter Communications
d. LPG or Natural Gas Service	NV Energy
e. Solid Waste Disposal Service	Waste Management
f. Cable Television Service	AT&T or Charter Communications
g. Water Service	Well (existing)

For most uses, Washoe County Code, Chapter 110, Article 422, Water and Sewer Resource Requirements, requires the dedication of water rights to Washoe County. Please indicate the type and quantity of water rights you have available should dedication be required.

h. Permit #		acre-feet per year	
i. Certificate #		acre-feet per year	
j. Surface Claim #		acre-feet per year	
k. Other #		acre-feet per year	

Title of those rights (as filed with the State Engineer in the Division of Water Resources of the Department of Conservation and Natural Resources).

Not applicable at this time.

10. Community Services (provided and nearest facility):

a. Fire Station	TMFPD - Pleasant Valley Volunteer/Foothill Drive Stations
b. Health Care Facility	Renown Regional Medical Center
c. Elementary School	St. Nicholas Orthodox Academy/Pleasant Valley Elementary
d. Middle School	St. Nicholas Orthodox Academy/Herz Middle School
e. High School	St. Nicholas Orthodox Academy/Galena High School
f. Parks	Galena Creek Regional Park/Davis Creek Park
g. Library	Washoe County - South Valleys Branch
h. Citifare Bus Stop	Not applicable

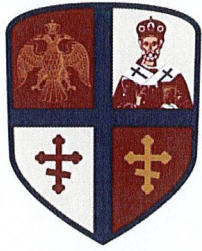

**ST. NICHOLAS**  
ORTHODOX CHRISTIAN ACADEMY  

---

R E N O • N E V A D A

**SPECIAL USE PERMIT**

Prepared by:



**JULY 8, 2021**

# **ST. NICHOLAS**

## **ORTHODOX CHRISTIAN ACADEMY**

### **Special Use Permit**

**Prepared for:**

St. Nicholas Orthodox Academy  
16255 South Virginia Street  
Reno, Nevada 89521

**Prepared by:**

Christy Corporation, Ltd.  
1000 Kiley Parkway  
Sparks, Nevada 89436  
(775) 502-8552

**July 8, 2021**



## Table of Contents

Introduction .....	1
Project Location .....	1
Existing Conditions .....	2
Project Background .....	6
Request Summary .....	6
Special Use Permit Findings .....	10

### List of Figures:

Figure 1 – Vicinity Map .....	1
Figure 2 – Aerial View .....	2
Figure 3 – Existing Conditions .....	4
Figure 4 – Existing Conditions .....	5
Figure 5 – Zoning .....	5
Figure 6 – Preliminary Site Plan .....	7
Figure 7 – Modular Building Elevation and Floorplan .....	9

### Appendices:

Washoe County Development Application  
 Owner Affidavit  
 Special Use Permit Application  
 Property Tax Verification

### Attachments:

Preliminary Site Plan



## Introduction

This application includes the following request:

- A **Special Use Permit** to allow for the establishment of a private school within the High Density Rural (HDR) regulatory zone.

## Project Location

The project site (APN # 045-210-01) includes 13.96± acres located at 16255 South Virginia Street (Old US 395). Specifically, the subject property is located on the west side of Virginia Street, south of Rhodes Road and north of Cheyenne Drive. Figure 1 (below) depicts the project location.



Figure 1 – Vicinity Map





## Existing Conditions

The property is currently developed with a single family residence and a historic commercial building and several smaller outbuildings that front Virginia Street. The Virginia Street structure has functioned as a residence, stagecoach stop, “divorce cottages” during the 1930’s to 1960’s, a church, and most recently a private school.

Surrounding uses include commercial (mini-storage) to the north, single family to the south, vacant land to the west, and a mix of vacant and commercial parcels to the east. Property to the west includes steep slopes extending up to the Interstate 580 right-of-way.

Figure 2 (below) provides an aerial view of the property and depicts existing onsite improvements while Figures 3 and 4 (following pages) provide photographs of the existing site conditions.

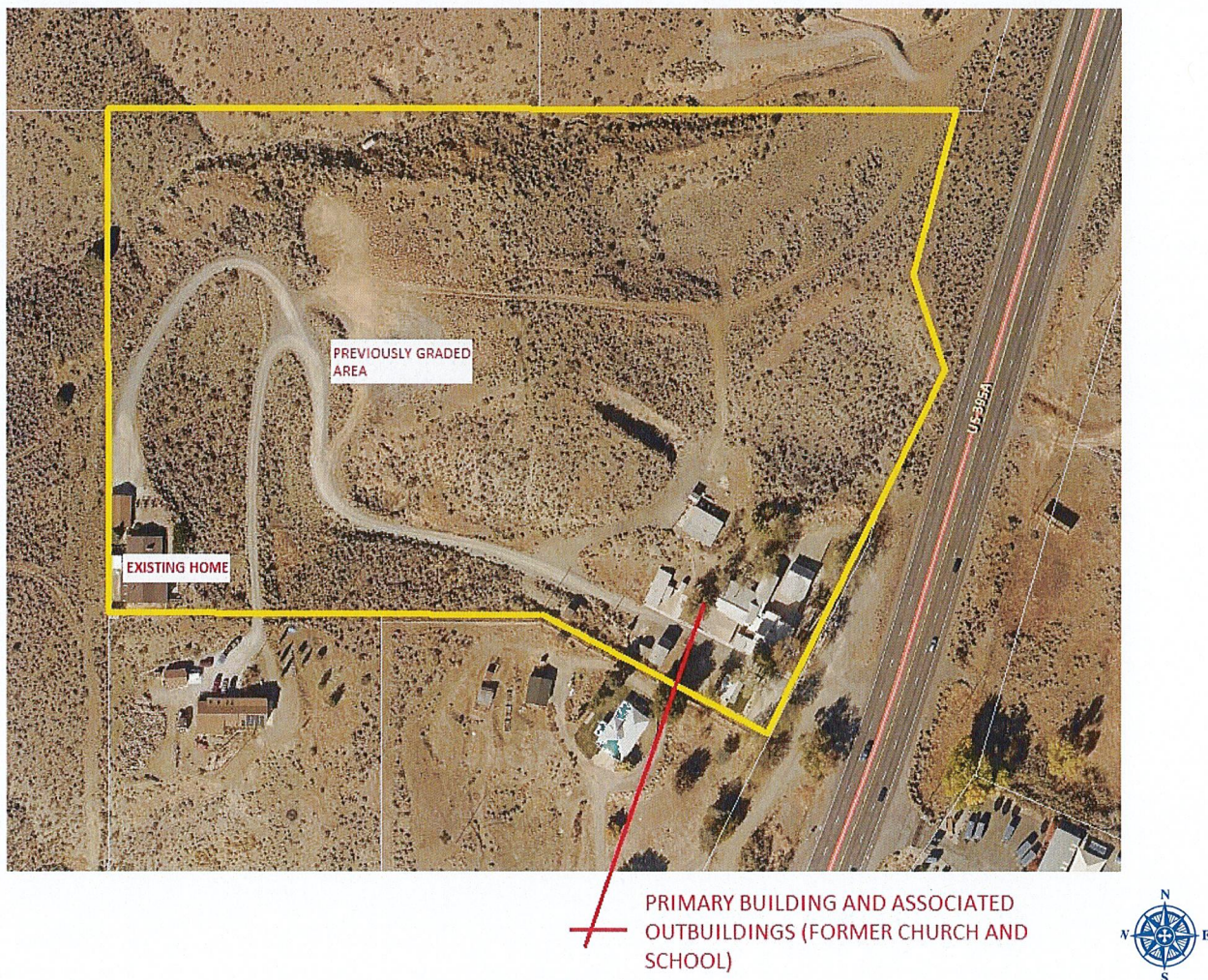
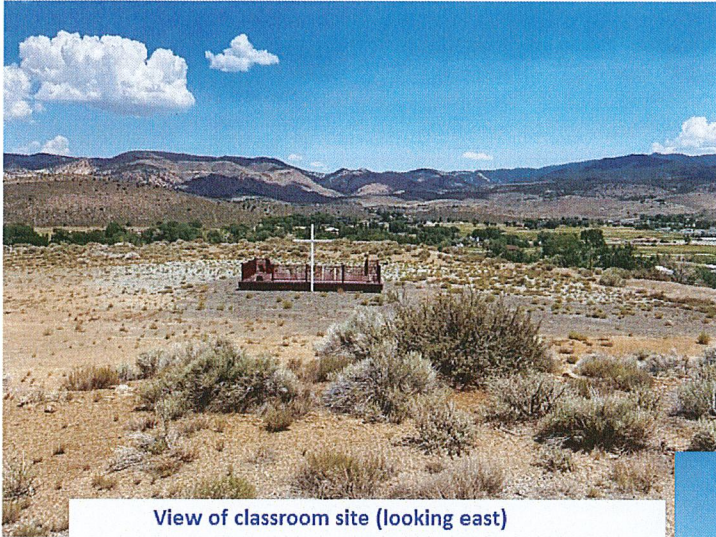
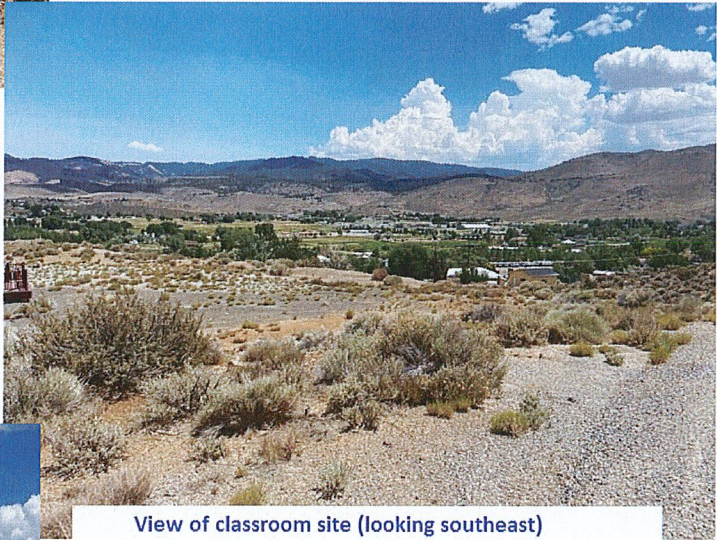

Figure 2 – Aerial View





View of classroom site (looking east)



View of classroom site (looking southeast)

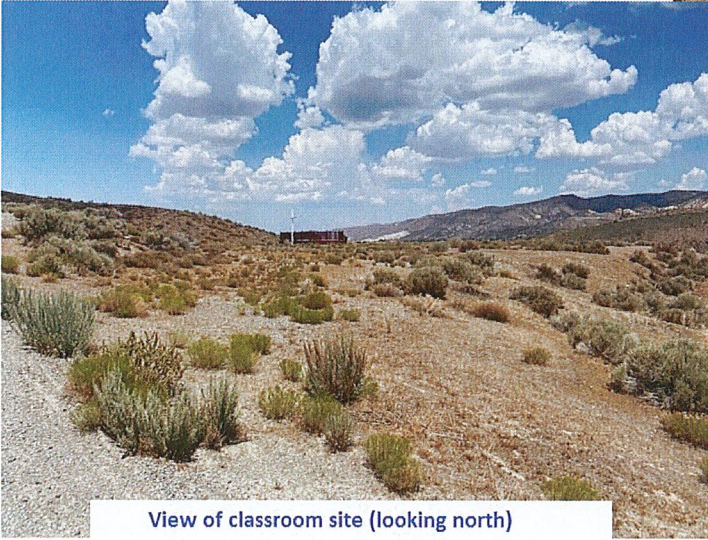

View of classroom site (looking north)

Figure 3 – Existing Conditions





Existing "commercial" building at east side of site

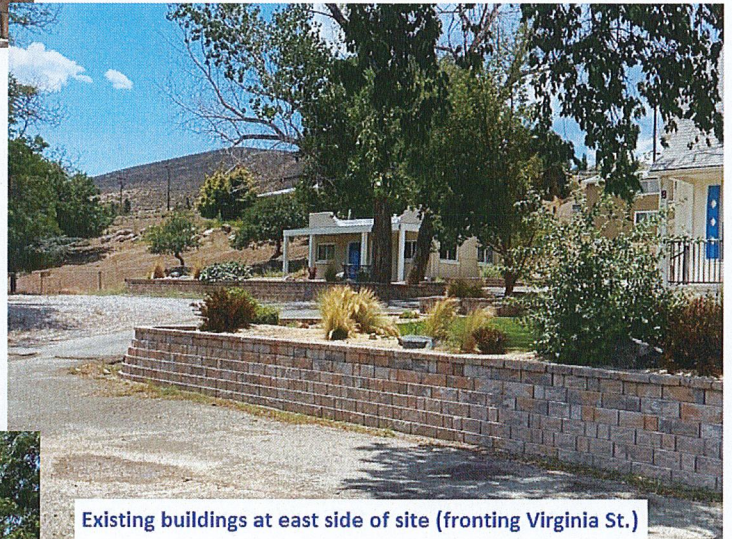

Existing buildings at east side of site (fronting Virginia St.)

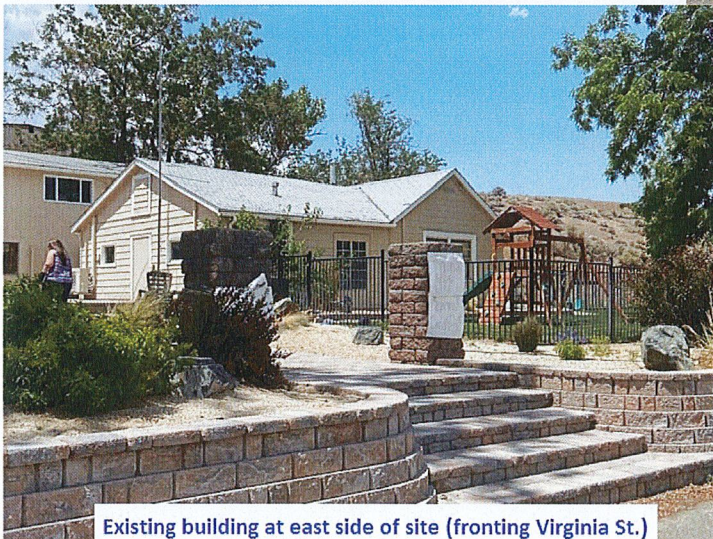

Existing building at east side of site (fronting Virginia St.)

Figure 4 – Existing Conditions





The 13.96± acre parcel is zoned High Density Rural (HDR). The area includes an eclectic mix of zoning including Neighborhood Commercial (NC) to the north and east, General Rural (GR) to the west, and Low Density Suburban (LDS) to the south. Figure 5 (below) depicts the existing zoning patterns in the area.



Figure 5 - Zoning



## **Project Background**

As noted previously, the project site has an eclectic history in terms of land use. Although the Assessor's office shows the primary building as being constructed in 1933, this is reflective of additions to the structure. The primary building (originally developed as a home) was built in the late 1800's and even served as a stagecoach stop between Reno and Carson City at one time. Cottages (existing outbuildings) were constructed in the 1930's and were rented to individuals seeking to establish Nevada residency in order to receive and expedited divorce.

The Glory Temple Church occupied the buildings for many years and operated a church and parochial school under a Special Use Permit (SUP) issued by Washoe County. In 2017, the church sold the property to the current property owners and the St. Nicholas Orthodox Christian Academy (St. Nicholas) was established. The school operated at the site until the end of the 2021 school year.

St. Nicholas operated with the assumption that the Glory Temple Church SUP ran with the land and was valid. However, in the process of completing improvements at the site in 2020, it was discovered that Glory Temple Church failed to maintain the validity of the SUP. Thus, no current SUP was in place to allow for St. Nicholas to operate. Therefore, this SUP request is needed to reestablish a private school use at the project site.

## **Request Summary**

The SUP request included with this application will allow for a private school use to be established at the project site. The Washoe County Development Code requires the SUP based on the existing HDR zoning. St. Nicholas ultimately plans to construct new private school facilities at the project site. The school will accommodate kindergarten through 12<sup>th</sup> grade and is envisioned to have a maximum of 100 students. The school will be located at the eastern portion of the site, adjacent to the existing historic home/commercial building.

Construction of the new school is a large undertaking and will require a significant amount of planning, engineering, and architectural design to complete. However, St. Nicholas wishes to continue to operate at the existing facility and with new temporary classrooms this fall. As a result, the SUP included with this application would permit the school use three temporary modular buildings (6 classrooms) that will be utilized while plans for the new facility are being developed.

This SUP calls for the three temporary modular classrooms to be located in the previously graded area central to the project site (as depicted in Figures 2 and 3). It is requested that the school be allowed to utilize the temporary classrooms for up to 3 years. This provides sufficient time to complete the design, permitting, and construction of the overall school plan.





Figure 6 (below) provides a site plan of the existing facilities and proposed temporary modular classrooms.

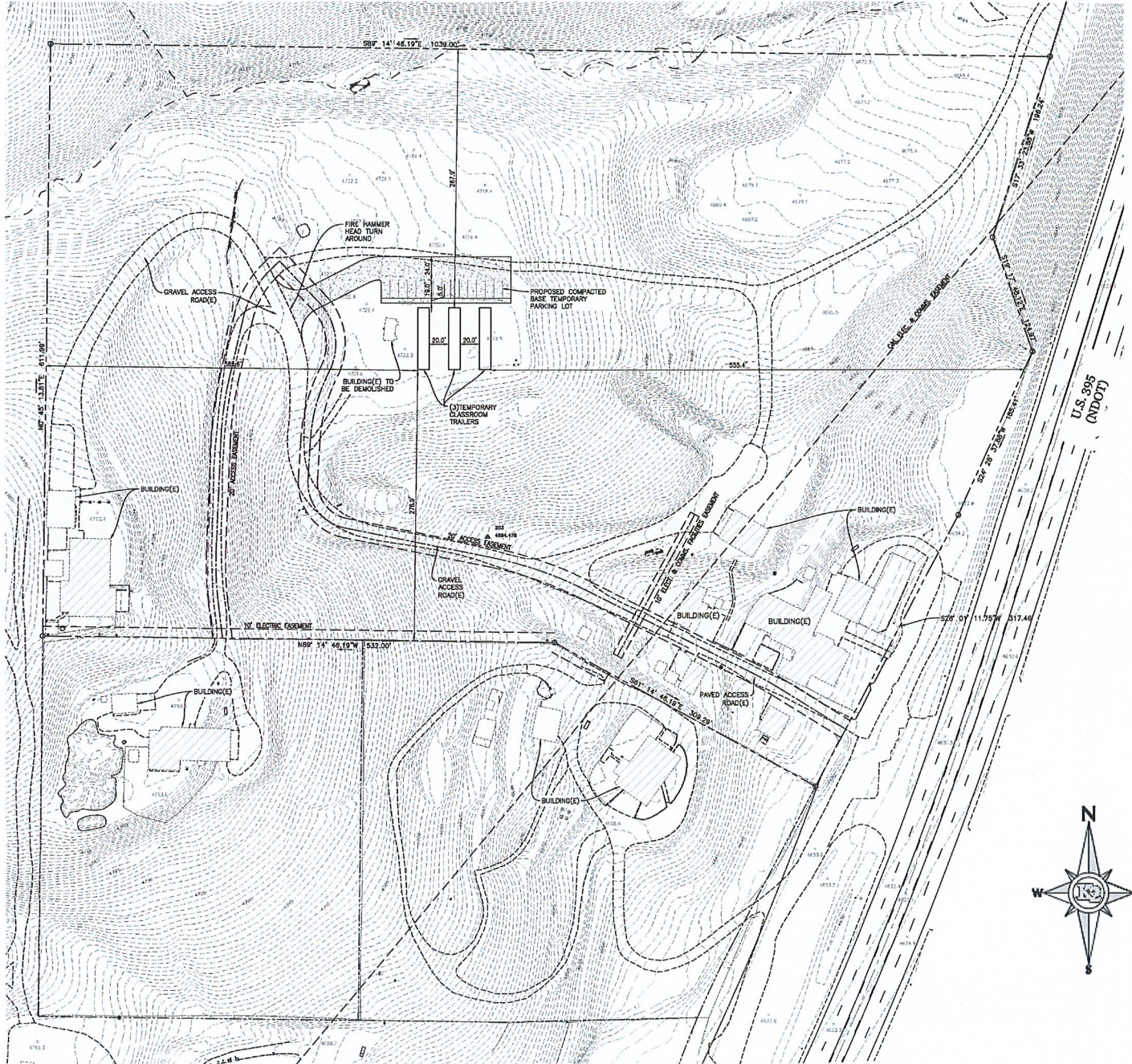

Note: Refer to attached full-size site plan.

**Figure 6 – Preliminary Site Plan**





The temporary classrooms proposed are essentially the first phase of the St. Nicholas Orthodox Christian Academy. This SUP is being submitted now to allow for the school to continue to operate at the site this fall. Plans for the ultimate buildout of the school are currently being prepared and are not completed at the time of this SUP filing. Thus, a supplemental SUP request or amendment to this SUP (based on Washoe County staff interpretation) will be submitted in the coming months to allow for a full review of the school master plan.

Currently, St. Nicholas has an enrollment of 10 to 12 students with 4 full-time and 1 half-time teachers. With the addition of the temporary classrooms, enrollment could slightly increase but no more than 15 students are anticipated. With such a small number of students and employees, allowing the temporary classrooms now will not result in any negative impacts to surrounding properties and simply permits the school to continue to operate at the site as it has since late 2017.

As depicted in Figure 6, the classrooms are situated in a row at the previously graded area that is accessed via the existing driveway that serves the home located at the southwest corner of the parcel as well as a home located on the parcel to the south. This driveway connects to the primary access along South Virginia Street. Parking for teachers as well as student drop-off will be located adjacent to the classrooms. A 50-foot fire turnaround will be located on the west side of the buildings ensuring circulation for emergency vehicles and will also allow parents to circulate out of the site during drop-off and pick-up hours.

Since the three classrooms are proposed on a temporary basis, it is requested that development standards be modified to allow for the use of an all-weather surface for access and parking areas adjacent to the temporary buildings. Similarly, it is also requested that landscaping standards be waived. Since the buildings will be removed within 3 years of the SUP approval date, the paving and landscaping serve no long term benefit. Also, the classrooms are located in an area that is not visible from South Virginia Street and no visual impacts to adjoining properties will occur.

The individual classrooms are approximately 1,536± in size (64 feet by 24 feet) and include a restroom. The remainder of the interior space will be dedicated to classroom and teacher workspace. The units themselves are fully self-contained and include fresh water, grey water, and black water tanks. The modular building company provides service for provision of fresh water and grey/black water disposal. Given that the buildings will not be permanently located onsite, it is not practical (or necessary) to connect the buildings with domestic services. Temporary power to the buildings will be extended from existing poles within the site and removed when the buildings are removed from the property. Figure 7 (following page) depicts the elevations and floorplan of the modular buildings that are proposed.

The addition of the three classrooms will have very little impact. In fact, the school has operated at the site in similar size and scale since 2017 and has proven to function appropriately. With only 10-15 students, activity at the site is limited. From an outside perspective, there will be little noticeable change at the site with implementation of this SUP request. School hours of operation are from 9:00 am to 3:00 pm Monday through Friday. These limited hours further ensure that impacts to the surrounding area will not occur.



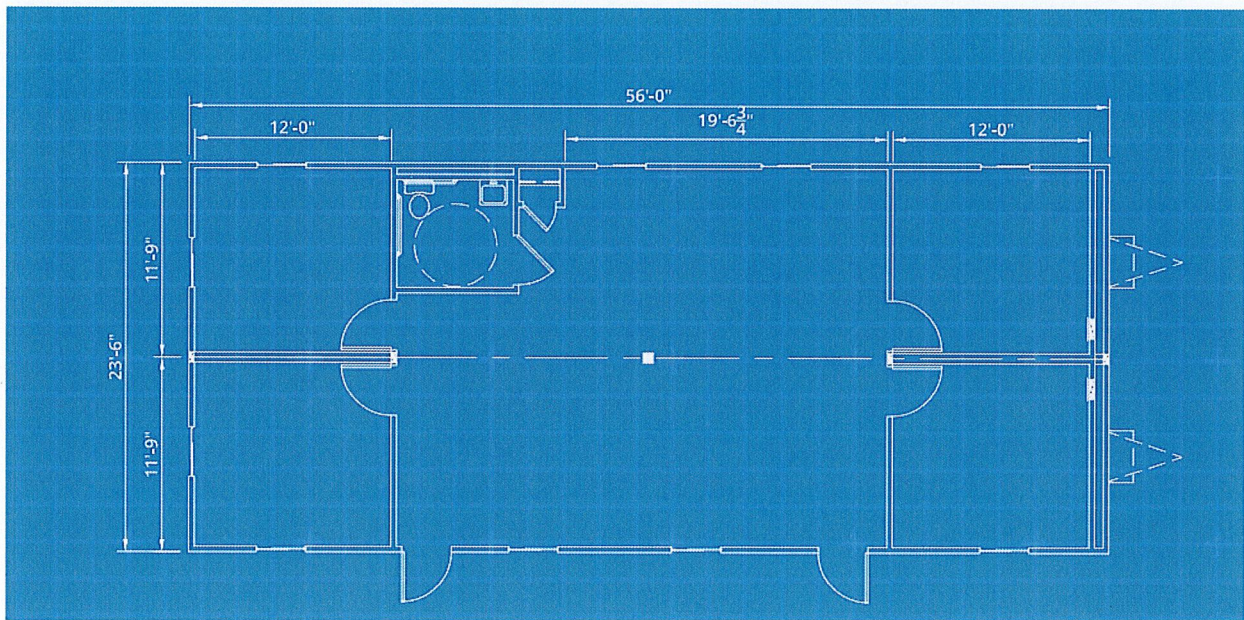

Figure 7 – Modular Building Elevation and Floorplan





With this initial phase, all classrooms will be located within the three modular buildings totaling 4,608± square feet. Based on trip generation data provided by the Institute of Transportation Engineers (ITE) for land use code 536 (Private School K-12), St. Nicholas is expected to generate 11 average daily trips (ADT) with 4 am peak trips and 1 pm peak trip. The peak hour trip generation rates are supported given the school's 9:00 am to 3:00 pm operating schedule. To put traffic generation into perspective, the peak hour trips generated by the school are less than one-half of one percent of the trip generation that would require a traffic impact analysis per Washoe County standards.

As noted, a second SUP (or amendment to this SUP) will be submitted in the upcoming months for the second phase of the St. Nicholas Orthodox Christian Academy which includes the overall school master plan. At that time, additional details will be provided to address the ultimate school buildout. The forthcoming submittal will include detailed engineering, architectural, and landscape plans along with supporting engineering reports, etc. Just like this initial phase, the Phase 2 plans will require a public review including a meeting with the South Truckee Meadows Citizens Advisory Board and a public hearing before the Washoe County Board of Adjustment.

This SUP, if granted, allows for the temporary modular classrooms to be located onsite for up to 3 years (36 months from date of approval). Should the Phase 2 SUP not be submitted or approved and the new school constructed within the 3-year time frame, this SUP request would expire and a new public process to establish a school use would be required.

### **Special Use Permit Findings**

In order to approve a Special Use Permit, the following findings must be made. Responses are provided in **bold face type**.

1. Consistency. The granting of the special use permit is consistent with the policies and maps of the Comprehensive Plan Elements and the Area Plan in which the property is located.

**The requested private school use is consistent with Division Three of the Washoe County Development Code and does not conflict with policies contained within the South Valleys Area Plan. The project is a low impact use and similar operations have proven to operate successfully at the site for several years.**

2. Adequate Public Facilities. Adequate utilities, roadway improvements, sanitation, water supply, drainage, and other necessary facilities must exist or will be provided.

**The new modular classrooms are fully self-contained with water and wastewater services provided by the building supplier. This is appropriate for the temporary use proposed. The 3 buildings (6 classrooms) and school operations will not result in significant traffic impacts and the site proposed for the buildings has already been graded. Thus, all impacts related to drainage, etc. can be easily mitigated.**





3. Site Suitability. The site must be physically suitable for the proposed use and for the intensity of development.

**The area proposed for the temporary classrooms has been previously graded and is well suited for the intensity of the proposed use. An all-weather surface will be provided to ensure proper parking and emergency access standards are met.**

4. Issuance Not Detrimental. Issuance of the permit may not be significantly detrimental to the public health, safety or welfare; have a detrimental impact on adjacent properties; or be detrimental to the character of the surrounding area.

**No negative impacts are anticipated with the granting of this SUP request. The private school and temporary classrooms are a very low intensity use. In fact, St. Nicholas has operated at the site since 2017 without incident. This SUP simply ensures that the use complies with Washoe County codes and allows the school to continue operation while plans for a new school facility are being prepared and processed.**



**St. Nicholas Temporary Classrooms**  
 1625 S Virginia St.  
 Reno, NV  
 APN: 045-210-01

Brandt T. Kennedy, P.E.  
 Jared A. Krupa, P.E.

**Revisions**

Date	7/08/21
Drawn	K2
Checked	BTK
Project No.	21-315

Site Plan

**C-1**

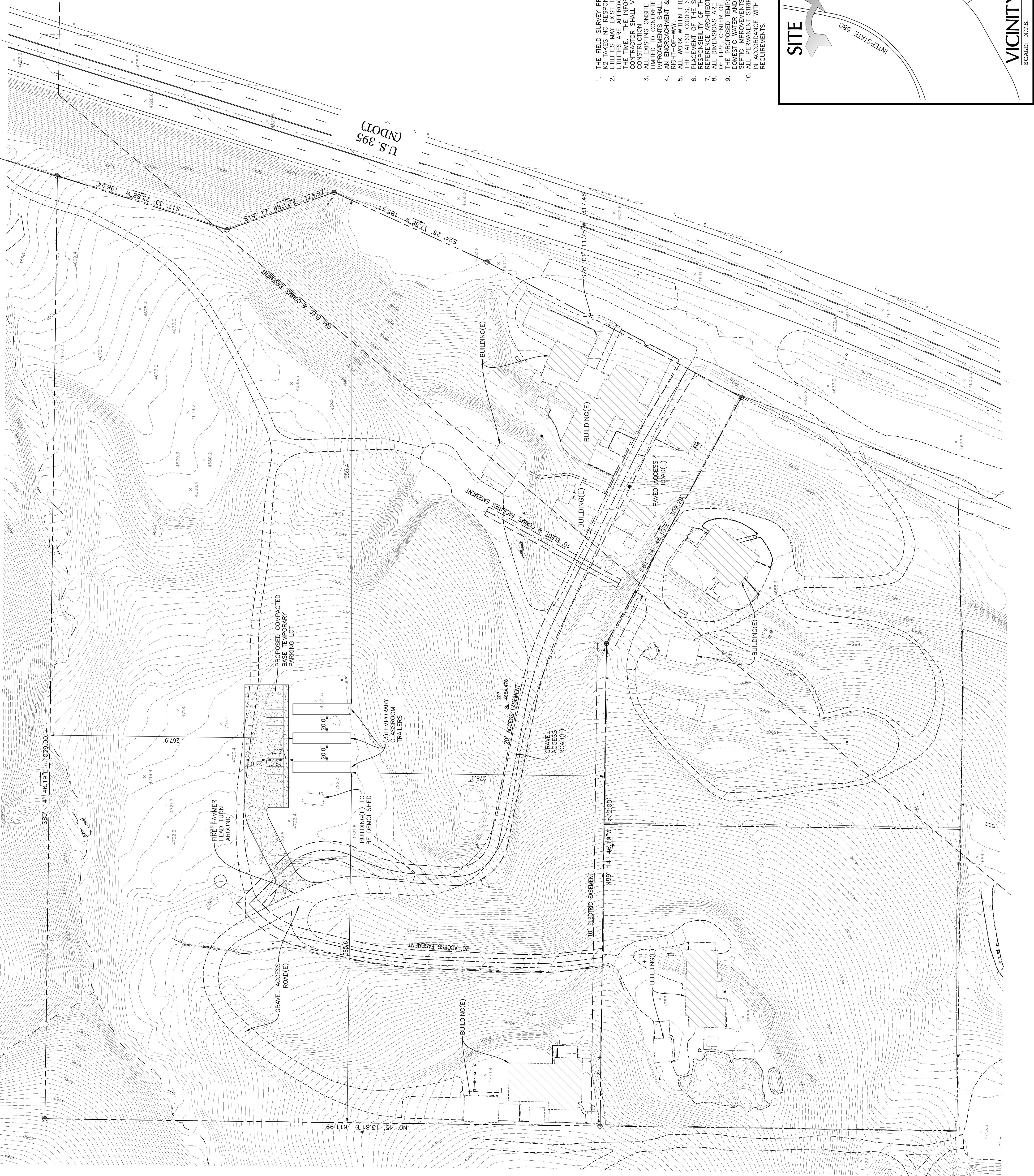
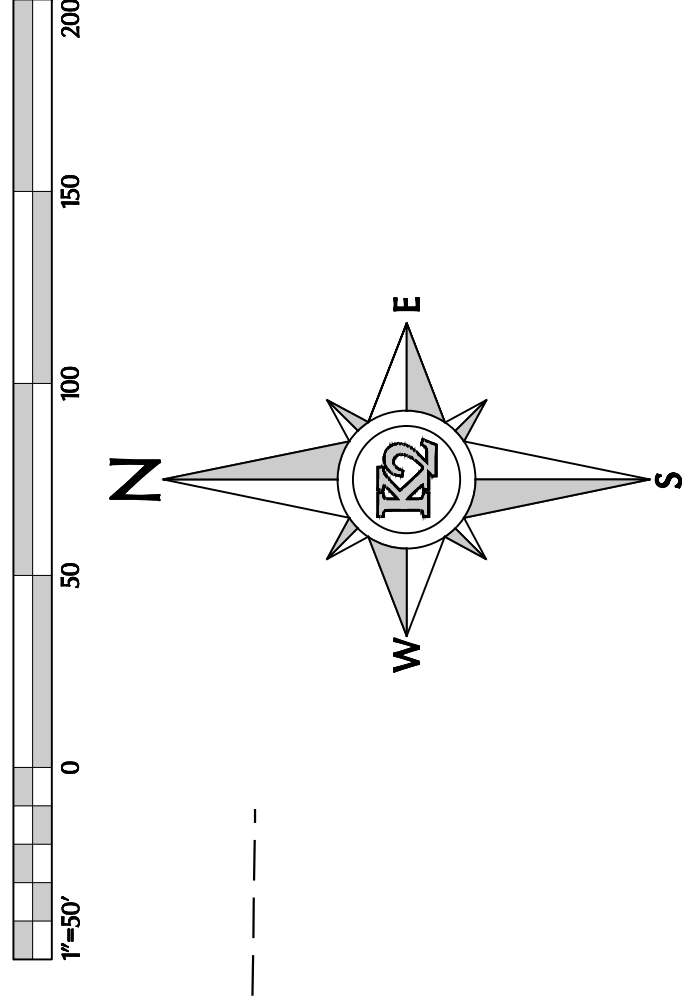

**NOTES**

1. THE FIELD SURVEY PREPARED BY SYNERGY MAPPING, INC. IS THE BASIS OF THIS DESIGN.
2. K2 TAKES NO RESPONSIBILITY FOR THE ACCURACY OF THE SURVEY.
3. UTILITIES MAY EXIST THAT ARE NOT SHOWN ON THE PLANS. THE LOCATIONS OF EXISTING UTILITIES ARE APPROXIMATE ONLY AND ARE BASED ON THE BEST AVAILABLE INFORMATION AT THE TIME OF THE SURVEY. THE CONTRACTOR SHALL VERIFY ACTUAL LOCATIONS OF EXISTING UTILITIES PRIOR TO CONSTRUCTION.
4. ALL EXISTING ON-SITE STRUCTURES AND ASSOCIATED SITE IMPROVEMENTS INCLUDING BUT NOT LIMITED TO CONCRETE PLAYWAY, DRIVEWAY APPROX., SIDEWALKS, LANDSCAPING AND UTILITY ARE TO REMAIN UNLESS OTHERWISE NOTED.
5. AN ENCROACHMENT & EXCAVATION PERMIT IS REQUIRED FOR ALL WORK WITHIN THE NDOT RIGHT-OF-WAY.
6. ALL WORK WITHIN THE NDOT RIGHT-OF-WAY SHALL BE CONSTRUCTED IN ACCORDANCE WITH THE LATEST CODES, STANDARD SPECIFICATIONS & DETAILS.
7. THE CONTRACTOR SHALL MAINTAIN THE REQUIRED SETBACKS SHALL BE THE RESPONSIBILITY OF THE CONTRACTOR.
8. REFERENCE ARCHITECTURAL PLANS FOR ALL BUILDING DIMENSIONS.
9. ALL DIMENSIONS ARE TO FRONT FACE OF CURB, FACE OF BUILDING, FACE OF WALL, CENTER OF THE CURB, CENTER OF MANHOLE OR PROPERTY LINE UNLESS OTHERWISE NOTED.
10. THE PROPOSED PERMANENT SEWER AND STORMWATER SYSTEMS SHALL BE INSTALLED PER DOMESTIC WATER AND SEWER WILL BE SERVICED REGULARLY. NO PERMANENT WELL OR SEPTIC IMPROVEMENTS ARE PROPOSED.
11. ALL PERMANENT STRIPING, SIGNAGE & TRAFFIC CONTROL IMPROVEMENTS SHALL BE INSTALLED IN ACCORDANCE WITH CURRENT "MANUAL ON UNIFORM TRAFFIC CONTROL DEVICES" (MUTCD) REQUIREMENTS.

